



**LAELOM**      **Laboratory for Advanced Electron and Light Optical Methods**  
**North Carolina State University College of Veterinary Medicine**  
 1060 William Moore Drive, Raleigh, North Carolina 27607  
**STANDARD OPERATING PROCEDURE**

Subject: Axio Imager M-1 Photomicroscope Instructions		Serial # 3516001517	
SOP No:	Version No: 1.7	Effective Date: May 11, 2010	Page: 2 of 21

- b. Focus on your **Specimen**.
  - c. Stop down the **Field Diaphragm (buttons #12 and 13 shown on page 5)** until you can see the edges of the **Field Diaphragm**.
  - d. Focus the **Condenser Assembly** with one of the **Black Knobs** on either side and behind the **Condenser Assembly** until the edges of the **Field Diaphragm** blades are sharp.
  - e. Open the **Field Diaphragm** with **buttons #12 and 13** until it is just out of the field of view.
16. Click on **Snap** at bottom of live screen, then click live screen off (X).
  17. Click on **Scale Bar** on **Workflow menu**.
  18. Click on area desired for **micrometer mark** on image.
    - a. Move cursor to left or right to adjust bar length.
    - b. Use cursor to grab micrometer number to move it away from the micrometer bar.
    - c. Use the cursor to grab the micrometer bar to move both number or bar around the image.
  19. To change the characteristics of the **micrometer bar**, click on **Show Properties** on the **Workflow** screen. Then, click on **A** (attributes) icon.
    - a. Highlight **scale bar** by clicking on it in the **Properties** menu.
    - b. Select line width.
    - c. Select color.
    - d. Select font and font size
    - e. Click on **Set as Default**.
  20. **For Annotations:** Click on **Draw Annotate** on **Workflow menu**.
    - a. Click on **A** icon at top of **draw annotation** screen.
    - b. Use cursor to define box for text.
    - c. Select characteristics for text after highlighting text on **draw annotations** menu.
    - d. Enter text in box.
    - e. Click on **OK** at bottom right of **draw annotation** screen.
  21. **To permanently merge micrometer bar and annotations with image:**
    - a. Click on **Annotations** at top of the screen.



Subject: Axio Imager M-1 Photomicroscope Instructions		Serial # 3516001517	
SOP No:	Version No: 1.7	Effective Date: May 11, 2010	Page: 4 of 21

OPERATION

Axio Imager      Axio Imager operation and function controls (motorized version)      Carl Zeiss

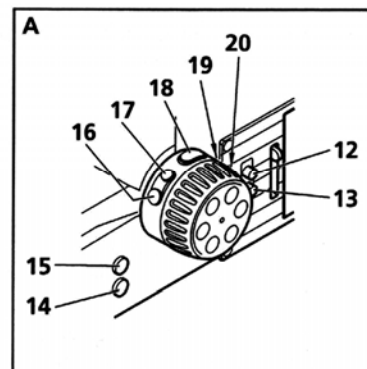
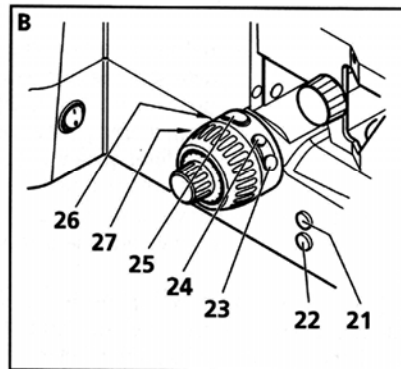
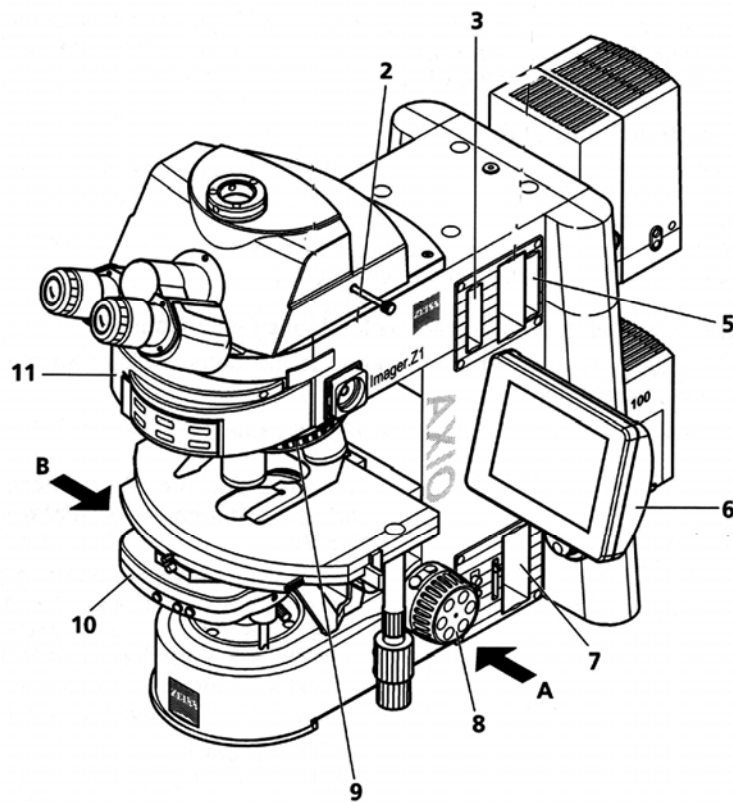

**LAELOM**      **Laboratory for Advanced Electron and Light Optical Methods**  
**North Carolina State University College of Veterinary Medicine**  
 1060 William Moore Drive, Raleigh, North Carolina 27607  
**STANDARD OPERATING PROCEDURE**

Subject: Axio Imager M-1 Photomicroscope Instructions		Serial # 3516001517	
SOP No:	Version No: 1.7	Effective Date: May 11, 2010	Page: 5 of 21

**Operating Instructions for the Zeiss Axio Imager M-1 Photomicroscopy System**

1. The numbers on the diagram of the Axio Imager are referred to in the instructions below. Clicking on <F1> from any window in the software will bring up instructions for those functions shown.
2. Turn on **Power Supply 231** for microscope (and **HBO 100 Power Supply** if doing epifluorescence work.
3. Turn on **Power Switch** on lower left rear of microscope stand.
4. Push on the **3200K Button** above the **Light Intensity Knob** behind the **Touchscreen**.
5. Turn on **Computer** and **Monitor**. Click on **OK**. Enter the password “laelom”.
6. Click on **Axiovision** icon to open up camera software.
7. Adjust interpupillary distance of **Oculars** and focus the **Oculars** individually on the sample.
8. Look at **Home** screen on **Touchscreen (#6)** and touch **Microscope** to select optical settings.
9. Select **Objective** desired on **Touchscreen**:

**List of Objectives and Their Capabilities**

<b>Objective</b>	<b>N.A.</b>	<b>Coverglass Thickness</b>	<b>Uses</b>
<b>1.25 X Plan Neofluar</b>	0.03	0.17 (#1.5)	BF*
<b>5 X Plan Achromat</b>	0.16	0.17	BF
<b>10 X Plan Achromat</b>	0.45	0.17	BF, Ph1**
<b>20 X Plan Achromat</b>	0.8	0.17	BF, Ph2, DIC***
<b>40 X Plan Achromat</b>	0.95	0.13-0.21	BF, Ph3, DIC
<b>63 X Oil Plan Achromat</b>	1.4		BF, DIC
<b>100 X Oil Plan Achromat</b>	1.4	<b>Not Installed</b>	BF, Ph3

\* Bright Field

\*\* Phase (the number corresponds to the appropriate condenser phase ring)

\*\*\* Differential interference contrast

**LAELOM**      **Laboratory for Advanced Electron and Light Optical Methods**  
**North Carolina State University College of Veterinary Medicine**  
 1060 William Moore Drive, Raleigh, North Carolina 27607  
**STANDARD OPERATING PROCEDURE**

Subject: Axio Imager M-1 Photomicroscope Instructions		Serial # 3516001517	
SOP No:	Version No: 1.7	Effective Date: May 11, 2010	Page: 6 of 21

10. Select **Contrast Manager** setting desired (**FL**-fluorescence; **BF**-bright field; **Ph**-phase contrast; **DIC**-differential interference contrast).

If the lens does not have certain capabilities, you will not be able to select that function on the **Touchscreen**.

The **Condenser Assembly (#10)** will automatically match the optical conditions selected for the **Objective**.

11. **RL-Shutter** opens the light path to the **Mercury** (fluorescence) **Light Source**.

**TL-Shutter** opens the light path to the **Halogen Light Source**.

Normally, selecting **FL** opens the **RL** path and closes the **TL** path. Selecting non-fluorescent conditions shuts the **RL** path and opens the **TL** path.

12. **Load** position drops the stage for loading a specimen. **Always drop the stage by pushing the Load button on the Touchscreen or by using the front buttons on the right side of the base (#14 and 15).**

13. The **Reflector** button opens up the **Menu** for **Fluorescence Cubes**:

**Cube Settings and Their Use**

Position	Use	Excitation (nm)	Beamsplitter (nm)	Emission (nm)
Module P & C	Open			
DIC TL	For using polarizers*			
49 DAPI	DAPI	335-383	Allows 395	420-470
38 HE GFP	FITC, GFP	450-490	495	500-550
43 HE	Rhodamine, TRITC	538-563	570	570-640
POL RL	For polarization work			

\*go to **BF** in **Contrast Manager**; select **DIC/TL** in **Reflector** menu, remove **DIC Prism** from **Objective** (if present), and swing **Substage Polarizer** lens into place manually.

In the computer program under **Microscope**, click on **Configure Microscope** to change **Reflector** settings.

**LAELOM**      **Laboratory for Advanced Electron and Light Optical Methods**  
**North Carolina State University College of Veterinary Medicine**  
 1060 William Moore Drive, Raleigh, North Carolina 27607  
**STANDARD OPERATING PROCEDURE**

Subject: Axio Imager M-1 Photomicroscope Instructions		Serial # 3516001517	
SOP No:	Version No: 1.7	Effective Date: May 11, 2010	Page: 7 of 21

13. The **Light Path Button** allows selections (at the top of the **Touchscreen**) for **100% Tube** or **100% Side Port** (the latter for fluorescence image capture with the **Monochrome Camera**).
14. **Automatic** allows automatic setups for viewing or capturing images with fluorescence.
15. **XYZ** allows z-stacking, but it is done better through the software on the computer. **Do not use this function of the Touchpad!**
16. **Condenser Assembly (#10)**
  - a. The **Condenser Assembly** is raised and lowered (for Köhlerization, described below) with the **Black Knobs** below and to either side of the **Condenser Assembly**.
  - b. The two **Knurled Silver Knobs** on the front of the **Condenser Assembly** are used to center the **Condenser Assembly**.
  - c. The buttons on the front of the **Condenser Assembly** can manually select a **Condenser Lens**, but it is preferable to work through the **Touchpad**, which automatically selects the appropriate **Condenser Lens** that matches the **Objective Lens** in use.
  - d. The **Left Buttons** on the front of the **Condenser Assembly** change the **Condenser Aperture**.
  - e. The **Right Buttons** on the front of the **Condenser Assembly** change the **Condenser Assembly Turret** position.
  - f. The **Center Buttons** on the front of the **Condenser Assembly** swing the **Upper Condenser Lens Element** in and out of the light path.
17. The buttons on the right side of the stand in front of the **Focusing Knob (#14 and 15)** raise and lower the stage.
18. The **Front Buttons** on the **Right Focusing Knob (#19 and 20)** change the **Condenser Aperture** setting.
19. The **Center Button** on the **Right Focusing Knob (#18)** toggles the **Halogen Light Path** on and off.

**LAELOM**      **Laboratory for Advanced Electron and Light Optical Methods**  
**North Carolina State University College of Veterinary Medicine**  
1060 William Moore Drive, Raleigh, North Carolina 27607  
**STANDARD OPERATING PROCEDURE**

Subject: Axio Imager M-1 Photomicroscope Instructions		Serial # 3516001517	
SOP No:	Version No: 1.7	Effective Date: May 11, 2010	Page: 8 of 21

20. The **Rear Buttons** on the **Right Focusing Knob (#16 and 17)** increase and decrease the **Halogen Light Source** intensity.
21. The **Front Buttons** on the **Left Focusing Knob (#26 and 27)** switch **Fluorescent Cube** positions.
22. The **Center Button** on the **Left Focusing Knob (#25)** toggles the **Fluorescent Light Path** on and off.
23. The **Rear Buttons** on the **Left Focusing Knob (#23 and 24)** increases and decreases the **Halogen Light** intensity.
24. The buttons on the left side of the stand in front of the **Focusing Knob (#21 and 22)** change **ND Filters** as do the buttons on **Module #7** on the right rear of the microscope base.
25. The **Field Diaphragm Buttons (#12 and 13)** open and close the field diaphragm. The two **Knurled Silver Knobs** on the front of the **Condenser Assembly** are used to center the image of the **Field Diaphragm** during Köhler illumination adjustments.
26. The **Diffuser Lens Slider** in front of the **Field Diaphragm Buttons (#12 and 13)** should be set in the **Diffuse** position to diffuse the image of the filament, except when trying to center the **Filament** (which can be viewed by placing a piece of lens paper on the glass surface of the halogen light path on the microscope base).

**LAELOM**      **Laboratory for Advanced Electron and Light Optical Methods**  
**North Carolina State University College of Veterinary Medicine**  
1060 William Moore Drive, Raleigh, North Carolina 27607  
**STANDARD OPERATING PROCEDURE**

Subject: Axio Imager M-1 Photomicroscope Instructions		Serial # 3516001517	
SOP No:	Version No: 1.7	Effective Date: May 11, 2010	Page: 9 of 21

**Further Instructions for Capturing Color (non-fluorescent) Images** (utilizing the **Axiovision** computer program and information on monitor screen):

1.     **Light Path Adjustments**
  - a.    Touch **Light Path** on **Touchpad**.
  - b.    Select **100% Tube** for viewing, with the **Beam Splitter** on the right side of the **Trinocular Head** pulled half way out (50% viewing, 50% capture).
2.    Make sure the **Halogen Light Source** is set at **3200K** (push the **3200K** button behind the **Touchscreen**).
3.    Choose an **ND (neutral density) Filter** with either **Buttons #21 and 22** or the buttons on **Module #7**.
4.    Click on the **Workflow** icon (on **Screen** when **AxioVision Program** comes up) in the **Toolbar** at the top of the **Computer Monitor Screen**.
5.    Click on **Color** at the top of **Workflow** window if **Fluorescence Workflow** screen is up.
6.    Click on **Live** icon..
7.    Click on **Exposure** icon at bottom of **Live Screen**.
8.    **White Balancing** is needed when changing specimens or magnifications. Click on lowest **AxioCam MR3** icon in **Workflow** window to bring up **Properties** screen.
  - a.    Under **AxioCam MR3: White Balance**:
    1.    Click on **Interactive** and place **Dropper** on white area of image and left click mouse.
    - or
    2.    Move to clear glass area of slide and left click on **Automatic**.
    3.    Click on **Exposure** icon again to adjust intensity level. Brightness and contrast can also be set from the **Live Properties** screen.
    4.    Close the **Properties** screen.
9.    Click on **Snap** on **Workflow** window to capture image.
10.   Click on **Save** in **Workflow** window.
  - a.    Click on **Client Images** folder (the default is MyDocuments/Client Images).

**LAELOM**      **Laboratory for Advanced Electron and Light Optical Methods**  
**North Carolina State University College of Veterinary Medicine**  
1060 William Moore Drive, Raleigh, North Carolina 27607  
**STANDARD OPERATING PROCEDURE**

Subject: Axio Imager M-1 Photomicroscope Instructions		Serial # 3516001517	
SOP No:	Version No: 1.7	Effective Date: May 11, 2010	Page: 10 of 21

- b. The image will be saved to the last used location.
  - c. Set up a new folder for your images.
  - d. Save as a TIFF file if you are taking it with you (the default is a Zeiss zvi file that saves the image linked to its metafile).
11. To add a **Micrometer Bar** to the image, which is *highly recommended if taking the image to another platform* (this can also be done in **Annotations** window):
- a. **Snap** image.
  - b. Click on **Scale Bar** icon in **Workflow** window.
  - c. Drag end of line to the size you want (it automatically scales micrometers).
  - d. To change between vertical and horizontal lines, grab the handle and move it.
  - e. To change the characteristics of the **Scale Bar**, click on **Show Properties** on **Workflow** window.
    - 1. Click on **Attributes** tab (after **Display** tab).
    - 2. Highlight object to be changed in upper right of screen.
    - 3. The **Scale Bar** and associated **Text** can be changed (and moved) independent of one another. Click on **Set as Default** to save the settings for future work.
12. To insert **Annotations**:
- a. **Snap** image.
  - b. Click on **Draw Annotation** in **Workflow** window.
  - c. Click on **“A”** icon.
    - 1. Click on **Images** and then click again to size box.
    - 2. To resize, click on **Feature Name** in upper right corner of screen. Grab the frame and resize it. You can also move it. Double click to restore box.
    - 3. After entering text, you can modify it in the window at the right side of the screen (color, text style, text font).
    - 4. When finished with annotation, click on **OK** at the bottom of the screen.
    - 5. Before saving, or after a saved image is opened, clicking on annotations on an image and then **Delete** will remove the annotations from the image.

**LAELOM**      **Laboratory for Advanced Electron and Light Optical Methods**  
**North Carolina State University College of Veterinary Medicine**  
1060 William Moore Drive, Raleigh, North Carolina 27607  
**STANDARD OPERATING PROCEDURE**

Subject: Axio Imager M-1 Photomicroscope Instructions		Serial # 3516001517	
SOP No:	Version No: 1.7	Effective Date: May 11, 2010	Page: 11 of 21

- a. To save **Annotations**, click on **Annotations** on top menu of **AxioVision** and select **Burn in Notations**. This also works to save **Scale Bars**. You can also select to burn in annotations on **Save** window.

**II. Polarized Light Images**

1. Select **BF**
2. Select **POL RL** under **Reflector**
3. Remove **DIC Slider** from objective (if present)
4. Swing in **Polarizing Lens** beneath **Condenser Assembly**.

**LAELOM**      **Laboratory for Advanced Electron and Light Optical Methods**  
**North Carolina State University College of Veterinary Medicine**  
 1060 William Moore Drive, Raleigh, North Carolina 27607  
**STANDARD OPERATING PROCEDURE**

Subject: Axio Imager M-1 Photomicroscope Instructions		Serial # 3516001517	
SOP No:	Version No: 1.7	Effective Date: May 11, 2010	Page: 12 of 21

**III. Start up for Fluorescence Work**

1. Perform steps 1-6 from Part I above.
2. Click on **Monochrome Camera**, then **AxioCam MR3\_2**.
3. Go to **Fluorescence Capture** section in this manual.

**IV. Fluorescent Imaging Instructions:**

1. Turn on **HBO 100 Power Supply**
2. Select appropriate cube for fluorochrome: Touch **Reflector** on **Touchscreen**, then **FL** under **Contrast Manager**.
3. Close **RL Shutter** when not viewing specimen.
4. **Capturing Fluorescent Images** (Utilizing the **Axiovision** Program):
  - a. Click on **Workflow** screen.
  - b. Click on **Fluorescence** at bottom of **Workflow** screen.
  - c. Click on top **AxioCam MR3\_2** icon.
  - d. Click on **Side Port** icon.
  - e. Click on **Dapi Viewing** (or other fluorochrome wavelength desired) on **Toolbar**.
  - f. Click on **Exposure** at bottom of **Live** screen.
  - g. Touch **RL-Shutter Close** on **Touchscreen** to save your fluorochromes.
  - h. Click on **Snap**.
  - i. Click on **Show Properties** under **Display** tab.
  - j. Click on **Min/Max**.
  - k. To return to **Viewing**, click on **Top Port** on **Toolbar**. Touch **RL-Shutter Open** on **Touchscreen**.
  - l. To pseudocolor images, right click on number (e.g., **"1"**) at bottom left of snapped image and select the appropriate color. Then click on **Colored Wheel**.
    1. Fluorescent images saved as TIFF files will normally be saved as monochrome files.

**LAELOM**      **Laboratory for Advanced Electron and Light Optical Methods**  
**North Carolina State University College of Veterinary Medicine**  
1060 William Moore Drive, Raleigh, North Carolina 27607  
**STANDARD OPERATING PROCEDURE**

Subject: Axio Imager M-1 Photomicroscope Instructions		Serial # 3516001517	
SOP No:	Version No: 1.7	Effective Date: May 11, 2010	Page: 13 of 21

2. To save images as pseudocolored files, open **Save As** dialog box, click on **Export** at lower right of screen and make sure color for **Channel Images** box is checked and **Generate Merged Image** is checked. Click on **Merged Images Only** to save one file for single fluorochrome. Otherwise, for 2 or 3 colors, check **Merged Images Only**.
  3. Have **Create a Project Folder** box checked. Click on **Set as Default** so that it will save files in this folder in the future.
  4. No **Metadata** file is saved with the **Export** function.
  5. Give **Image Name** for a given experiment.
5. **To adjust noise:**
- a. Click on **Colored Wheel** to return to gray scale image.
  - b. Click on **Properties** icon.
  - c. Click on **Min/Max** icon.
  - d. Grab the left side of the histogram and pull to the right.
6. **To Capture 3 Different Fluorochrome Images:**
- a. Click on each **Color Button** on **6D Acquisition** screen.
  - b. Bring up **Fluorescence** work group and click on the two **Camera** icons.
  - c. Right click to toggle channels on and off. Left click on desired channels.
  - d. Click **Measure** (opens live window). Then, click on **OK**. Repeat for all channels
    1. Turn on the histogram and adjust so that right side is short of histogram frame, to keep it from being oversaturated.
    2. The **Pseudocolor Bar** at the bottom of the screen should be highlighted. Any red in the image will indicate overexposure.
    3. Under **Extended Parameters**, you can set the **Maximum Pixel Intensity** at 75-80% if you are getting oversaturation routinely when clicking on **Measurement**.
  - e. After all three colors are measured, click on **Start** and all three will be captured and merged.
  - f. Click on **Gallery View** at the bottom left of the screen to see all of the channels at once.
  - g. Click on **Save** to save image. The **Merged Image** will also have each channel saved separately as a monochrome file.

**LAELOM**      **Laboratory for Advanced Electron and Light Optical Methods**  
**North Carolina State University College of Veterinary Medicine**  
1060 William Moore Drive, Raleigh, North Carolina 27607  
**STANDARD OPERATING PROCEDURE**

Subject: Axio Imager M-1 Photomicroscope Instructions		Serial # 3516001517	
SOP No:	Version No: 1.7	Effective Date: May 11, 2010	Page: 14 of 21

- h. The **Metadata** for each file is lost when the file is exported out of the **Axiovision** program.
  - i. The **Automatic** and **100%** (camera weighting) boxes should be checked for most samples. If you have a single cell that is oversaturated, decrease the weighting percent. Check each **Channel** exposure by clicking **Channel** and **Measure**. Change camera weighting slider % appropriately.
    - 1. Since **Auto** is the most unweighted setting for the different channels, it gives the rawest data. If doing semiquantitative work, make the settings with **Fixed** button on and take all subsequent exposures at the same initial setting.
    - 2. If you change weighting with **Auto** checked, the program still remembers your settings.
    - 3. If you check **Fixed**, you can adjust each channel intensity. If red pixels appear (indicating over saturation), decrease weighting percent with slider.
  - j. Prior to starting an experiment, on **Multidimensional Acquisition** screen, type in **Image Name**, and all files for the different channels will be put in the same named folder, with the folder name prefix associated with each file. The **Metafile** folder is associated with all the image channels in the folder.
7. The **Close All** button on the **Toolbar** closes all windows simultaneously, while asking you if you want to save any unsaved images before wiping them out.
8. **To Repeat Experimental Conditions:**
- a. Save images as **zvi Files**.
  - b. Go to **Multidimensional Acquisition** screen.
  - c. Click on **Experiment**.
  - d. Click on **Reuse**.
  - e. Browse to previous file or previous open image.
  - f. Click on **Open**.
9. Going to **Tools, Options, Naming** allows you to give a label to an image.

**LAELOM**      **Laboratory for Advanced Electron and Light Optical Methods**  
**North Carolina State University College of Veterinary Medicine**  
1060 William Moore Drive, Raleigh, North Carolina 27607  
**STANDARD OPERATING PROCEDURE**

Subject: Axio Imager M-1 Photomicroscope Instructions		Serial # 3516001517	
SOP No:	Version No: 1.7	Effective Date: May 11, 2010	Page: 15 of 21

**V. Z-stacking and Deconvolution**

1. Go to **6D Acquisition** and follow procedures for acquiring multiple fluorescent images.
2. Click on **Measure** for each channel. Turn on **Histogram** and adjust exposure time to get histogram below half way across scale or less (with iterative algorithm, you will very likely oversaturate if over ½ scale). You are trying to leave enough dynamic range in captured image to avoid saturation in deconvolved image.
3. Assign an **Image Name** for a given experiment.
4. The **Min/Max** button at the bottom of the screen normalizes each slice in a stack. **To avoid this**, click on **Min/Max** in the **Properties** dialog box instead (either method works for a single image).
5. To change **Weighting**, click on the **Color Bar** icon at the top of the **Properties** screen, click on channel desired and increase/decrease weighting. You can also go to **Gallery View** at the bottom of the screen and click the 2<sup>nd</sup> icon from the right. Then, click on individual images and adjust weighting as desired.
6. Click on **Create Image** to save gallery. No meta data is associated with the images. Holding down the **Control** key while clicking on gallery images allows you to create selections to extract. Clicking on **Extract Selection** allows you to remove poor images from a z-stack.
7. **Setting up Z-Stacks**
  - a. Click on **Experiment** tab on **Multidimensional Acquisition** screen and click on **Z-stack** box or click on **Z-stack** tab at the top of the **Multidimensional Acquisition** screen.
  - b. Set the number of **Slices** and **Slice Distance** or click on **Optimal Distance** tab, which finds the proper number of slices based on the **Objective** in use and the **Wavelength(s)** in use to satisfy the Nyquist criteria.
  - c. **Select the stack**
    1. Find the center of the object and click **Center** button or click on the **Start/Stop** button and go to one extreme and then click on **Stop** position for the other extreme, looking through the microscope.
    2. Another method is to click on the box at the end of the **Start** line, which opens a live window. Then, focus way up or way down (either can be the start or stop position)

**LAELOM**      **Laboratory for Advanced Electron and Light Optical Methods**  
**North Carolina State University College of Veterinary Medicine**  
 1060 William Moore Drive, Raleigh, North Carolina 27607  
**STANDARD OPERATING PROCEDURE**

Subject: Axio Imager M-1 Photomicroscope Instructions		Serial # 3516001517	
SOP No:	Version No: 1.7	Effective Date: May 11, 2010	Page: 16 of 21

3. Click on **Optimal Distance**-gives slice distance needed based on wavelength and numerical aperture (oversampling by 2X to satisfy Nyquist Theory), approximately 2X the focal length of the lens
  4. Click on **3-dot box** at end of **Start** line, which gives live window from last window on which exposure was set
  5. Move to one end of the Z-stack (either way is fine) and click **OK**
  6. Click on **3-dot box** at end of **Stop** line
  7. Move to other end of Z-stack and click **OK**
  8. Now window should show # of slices and slice thickness
  9. The Z-stack always is collected from the top down (to use the force of gravity to help stabilize the movement of the stage evenly).
  10. If the **All Channels Per Slice** box is checked, it will collect all channels at each slice level (which is recommended for co-localization work); if the box is unchecked, it will collect all slices with one channel, then switch to the next channel and collect all slices again (This is a good method for sensitive fluorochromes). **It is much faster to collect all slices with one channel and then switch to the next channel (the second option above).**
  11. **Z-stack Navigation** allows you to navigate through the whole stack of slices to see individual slices.
  12. The control **Settings Before/After Z-stack** is not really used.
  13. **To Collect the Z-stack**, click on **Start** at the lower right of **Multidimensional Acquisition** menu.
  14. After capture, you can go through the stack with the slider at the bottom of the screen.
8. **For Deconvolution**, you want to capture **all** of the light from the specimen, even the faint light above and below the object of interest to be able to deconvolute the image with the point-spread function. Need the point-spread function for **each Objective** (based on the objective and wavelength(s) being used). **Make sure you go well above and below the information from the image before deconvolution.**

**LAELOM**      **Laboratory for Advanced Electron and Light Optical Methods**  
**North Carolina State University College of Veterinary Medicine**  
1060 William Moore Drive, Raleigh, North Carolina 27607  
**STANDARD OPERATING PROCEDURE**

Subject: Axio Imager M-1 Photomicroscope Instructions		Serial # 3516001517	
SOP No:	Version No: 1.7	Effective Date: May 11, 2010	Page: 17 of 21

- a. You can **Create a Measured Point-Spread Function** based on a 0.2  $\mu\text{m}$  fluorescent bead. If this is done properly, you get the best images. On the other hand, a **Theoretical Point-Spread Function** is usually adequate.
- b. Once the Z-stack is captured, can then **Process the Image**
  1. Click on **Processing**
  2. Click on **Deconvolution, Deconvolution**
    - a. Click on **Point-Spread Function**. Check that excitation and emission boxes are filled in and the **Objective NA** is correct
    - b. Click on **PSF (Correct Extended)** to check refractive index of embedding media
    - c. Select appropriate embedding medium from menu
    - d. There are several methods to **Deconvolve an Image and Produce a 3-D Rendering**:
      1. **Iterative**-only truly quantitative algorithm; does as many iterations as needed to optimize; with thickest specimen, would need the iterative algorithm; thickest specimen to use with 63X objective would be 190  $\mu\text{m}$ ; to find specimen thickness for a given objective, to to **Microscope, Configure Microscope** (MTB 2004 Configuration dialogue box appears), **Click on objective of interest** to see the working distance; the working distance is the *theoretical* limit to the size of the Z-stack (very specimen-dependent). **Full Iterative** is best for submicrometer detail.
      2. **Fast Iterative**-only 8 iterations of deconvolution
      3. **Nearest Neighbor**-really fast method, dirty and cheap; looks at adjacent slices (not a Nyquist sampling method)- deblurring algorithm
      4. **PSF Theoretical**-this creates a PSF for each objective and wavelength; go to **Processing, Deconvolution, Create PSF**; do a Z-stack on a 0.2 $\mu\text{m}$  fluorescent bead; sample at a slice thickness **smaller** than Nyquist sampling number (approximately 150 nm slice thickness for these beads)
- c. Click on **Processing, Deconvolution, Algorithm, Nearest Neighbor, and Theoretical** (or **Custom Measurement** if you made one from fluorescent beads)

**LAELOM**      **Laboratory for Advanced Electron and Light Optical Methods**  
**North Carolina State University College of Veterinary Medicine**  
1060 William Moore Drive, Raleigh, North Carolina 27607  
**STANDARD OPERATING PROCEDURE**

Subject: Axio Imager M-1 Photomicroscope Instructions		Serial # 3516001517	
SOP No:	Version No: 1.7	Effective Date: May 11, 2010	Page: 18 of 21

- d. **Normalization** should be on **Autolinear**
  1. **Clip** sets any negative values to 0 and positive values to the brightest level; assumes no saturation (4096 is highest brightness level)
  2. **Autolinear** sets the darkest pixel at 0 and the brightest at 4096 (no quantification is possible)
  3. **Match Input** is not used
- e. Click on **Enable Z-stack Correction** if you know bleaching of your fluorochrome is occurring
- f. Apply **Strength of Algorithm** (high is grainy and low is fuzzy; usually use one click above **Medium**)
- g. Click on 6<sup>th</sup> icon from left at the bottom of the screen to do an **ROI** (region of interest). Move box around on screen and resize to select the **ROI**. This will allow quicker acquisition than doing the entire screen and thus saves time.
- h. Click on **PSF Function** of **Deconvolution** screen to check settings for specific fluorochrome
- i. If **Axial Scaling box** (section thickness) is blank (scalings turned off), go to **Measure** and check and highlight **Automatic scaling**
- j. Look at **PSF (extended)** or **Deconvolution** page, click on **Enable Correction** and click on appropriate **embedding medium** (choose from drop-down menu). Click on **OK**
- k. Go back to **Processing, Deconvolution** and click on **OK**. Click on **3-D View** when it is finished. Drop resolution from **Precise** to **Fast** at right of screen
- l. Click on **Settings**, click on **Illumination** and adjust brightness
- m. Find brightest slice on both channels and click on **Min/Max box**
- n. **To Select an ROI** (and decrease the processing time for the image by eliminating the rest of the non-processed image):
  1. Click on the rectangle in the **Rectangle Button** at the bottom of the screen
  2. Resize
  3. Hold **Ctrl Key** down and left click in ROI. This will copy and paste the ROI into a new window

**LAELOM**      **Laboratory for Advanced Electron and Light Optical Methods**  
**North Carolina State University College of Veterinary Medicine**  
 1060 William Moore Drive, Raleigh, North Carolina 27607  
**STANDARD OPERATING PROCEDURE**

Subject: Axio Imager M-1 Photomicroscope Instructions		Serial # 3516001517	
SOP No:	Version No: 1.7	Effective Date: May 11, 2010	Page: 19 of 21

- o. Click on **Profile** to put intensity profile on image. You can compare different profiles for different algorithms. Base line elevation shows noise and the narrowness of the peaks shows resolution (to some extent)
- p. Clicking on the **XY Axis** button (two overlapped ovals) on the left side of the screen allows rotation in any direction
- q. Clicking on the **Overlapped Squares** button at the bottom of the screen turns the frame on and off
- r. Clicking on the ruled **Measurement** button at the bottom of the screen gives measurements on the axes in  $\mu\text{m}$
- s. Clicking on the **Three Axes** button at the bottom of the screen shows the axes in color
- t. Clicking on the **Home** button at the bottom of the screen takes you back to the whole stack view
- u. Clicking on the **Swirl** button at the bottom of the screen allows you to grab a rendering and spin it in any direction
- v. The **Gradations** button at the left side of the screen allows you to zoom the image in and out
- w. The **Vertical Spin** button allows spinning on the y-axis
- x. The **Horizontal Spin** button allows spinning on the x-axis
- y. The **Circle with a Dot in the Center** button allows spinning on the z-axis
- z. The **Magnifying Glass** button allows you to zoom by moving mouse around
- aa. The **Hand** button allows you to pan around image
- bb. The **Helicopter** button allows you to move around the image: click on the left mouse button to move forward into the image (steering with the mouse); if you hold both mouse buttons down and it will reverse, but only in a straight line
- cc. **To Compress Z-stack Slices into one Image**, click on **Cut View** at bottom of screen and **MIP (Maximum Intensity Projection)** at the right side of the screen; the image in the center of the screen is a 2-D compression; click on **Create Image**

**LAELOM**      **Laboratory for Advanced Electron and Light Optical Methods**  
**North Carolina State University College of Veterinary Medicine**  
1060 William Moore Drive, Raleigh, North Carolina 27607  
**STANDARD OPERATING PROCEDURE**

Subject: Axio Imager M-1 Photomicroscope Instructions		Serial # 3516001517	
SOP No:	Version No: 1.7	Effective Date: May 11, 2010	Page: 20 of 21

- dd. **Another Method to Make 2-D Compressed Image:** go to Z-stack collected and click on **Processing; Extended Focus** should show **Wavelets**; no **Alignment** is needed; **New Image** should be **on**; click on **OK**
- ee. **MIP** looks at each pixel in stack and selects the brightest one from each slice
- ff. **Extended Focus** looks at the contrast of each pixel at each Z-stack slice; this is good for bringing long, sinuous objects into focus (e.g., neurons)

**V Capturing a Point Spread Function** (Abbey Wood, April 2, 2009)

- 4. **Camera Settings: Linear Mode**, 100% exposure to get full gray levels and capture all raw data available.
- 5. Place slide on stage and find an area with nicely separated spheres.
- 6. Focus on a sphere and obtain a Z-stack using the “center” mode to produce a stack that is equidistant on either side of focus.
- 7. View in 3-D mode to check shape of the point spread function.
- 8. If the shape appears one-sided or otherwise not an hourglass, check the histogram of the image and make sure that it is stretched. Manipulation of the histogram should correct the 3-D appearance.

**LAELOM**      **Laboratory for Advanced Electron and Light Optical Methods**  
**North Carolina State University College of Veterinary Medicine**  
1060 William Moore Drive, Raleigh, North Carolina 27607  
**STANDARD OPERATING PROCEDURE**

Subject: Axio Imager M-1 Photomicroscope Instructions		Serial # 3516001517	
SOP No:	Version No: 1.7	Effective Date: May 11, 2010	Page: 21 of 21

### Staff Adjustments

1. Click on **Microscope**  
Click on **Configuration**  
Type **Administrative Password (12345)**  
Toggle **Personal Settings** on  
Make sure **Administrative Privileges** is checked
2. On **Touchscreen**, tap on **Home, Settings, Extra, and Classic**  
-this allows you to Köhlerize and set all optical conditions and store the settings by pressing the button on the back side of the light adjusting knob area on the base of the stand.
3. The **Fluorescence Light Source Bulb** should be changed at **300 hours of use**.
4. Go to **Programs, Carl Zeiss, MTB 2004 Config, 6X Motorized Reflector Changer:**  
For Example: **Position 6**  
Find polarizer in list (Analyzer Trans. Light), click on **New Configuration 1**, then click on **Write Configuration to Hardware; Pol RL** button under **Reflector** should be set up
5. To find information about any function (accessing on-screen documentation), click on F1